



Dishwashing

EVO Generation - Concept

DISHWASHER CO-500 DD

<u>DIMENSIONS</u>		<u>Article</u>	<u>Packed</u>
Length	mm	600,00	690,00
Depth	mm	600,00	775,00
Height	mm	830,00	1.105,00
Weigth	Kg	60,00	67,00
Volumen	m3	0,30	0,46

ELECTRICITY

<u>Electric power</u>	KW	
230V -1+N		2x6+T - 40 A
230V - III		3x2,5+T - 25 A
400V - III+N		4x2,5+T - 20 A

WATER

Water consumption (lit/h)	72,00
Pressure (Kg/cm2)	2 ÷ 4

GAS

Not used

STEAM

Not used

AIR

Not used

LEVEL SOUND

(dB) **63,00**

DISHWASHER CO-500 DD

Front loading dishwasher - EVO Generation - Concept range.
 Hourly production: 40 baskets/hour - 720 dishes/hour.
 Clearance (max ware height): 380 mm.
 Valid for GN-1/1 trays
 Wash cycles: 90".

Made of stainless steel.

Full Double skin body to isolate machine's noise from the environment . The door has double skin with special pressed isolation material, and stamped finishing to improve noise isolation and to keep the heat inside the machine. Rock counterbalanced door. Double spring and stainless steel hinge system. The case allows the placement of the machine under surfaces of 850 mm height.

Double rotating wash and rinse systems, above and below, made of stainless steel.

Wash pump: 600 W.

Tank with 2.8 kW heating element.

Tank capacity: 20 litres.

Boiler heating elements: multipower 1,8 / 2,8 / 3,7 / 5,6 kW.

Boiler capacity: 7 litres.

Water consumption: 2.4 litres/rinse.

Thermostatic temperature control: washing at 60°C and rinsing at 90°C.

Security thermostats.

Built-in automatic rinse dispenser and detergent doser.

Built-in non-return valve.

Safety magnetic switch for door opening.

Adjustable legs.

Water protection rating: IPX4

Total power: multipower 2,4 / 3,4 / 4,3 / 6,2 kW.

Dimensions: 600 x 600 x 830 mm.

Baskets equipment: 1 x CT-10, 1 x CP-16/18 and 1 cutlery container.

<u>Connections points</u>	<u>X</u>	<u>Y</u>	<u>Z</u>	<u>Diameter</u>	<u>Information</u>
ELECTRICITY	210	50	65		
SOFT COLD WATER	305	50	65	3/4"	
DRAIN	370	50	65	30 x 25	

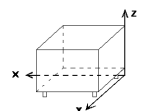

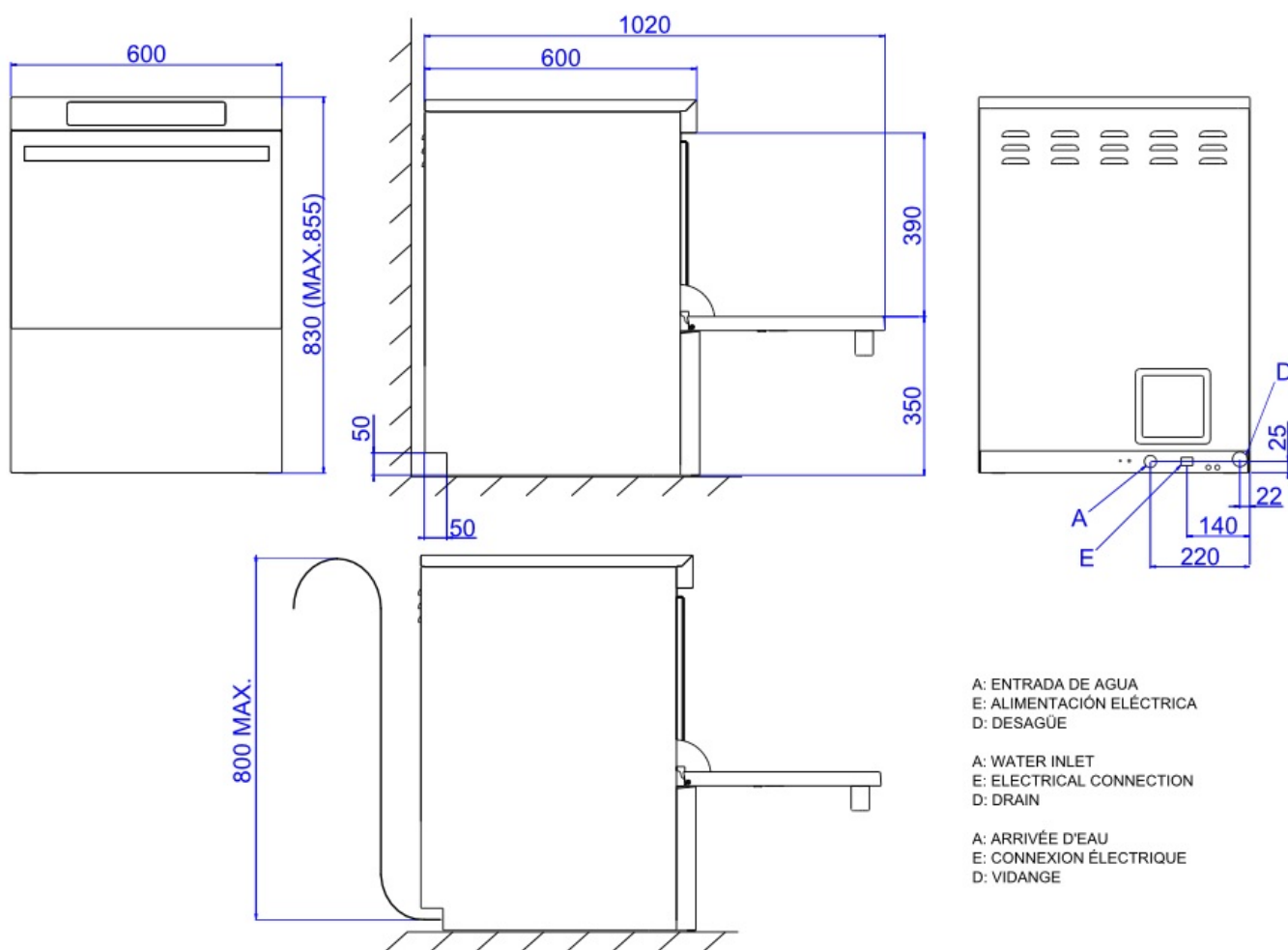

- A: ENTRADA DE AGUA
- E: ALIMENTACIÓN ELÉCTRICA
- D: DESAGÜE

- A: WATER INLET
- E: ELECTRICAL CONNECTION
- D: DRAIN

- A: ARRIVÉE D'EAU
- E: CONNEXION ÉLECTRIQUE
- D: VIDANGE